

Model 1641

Mobile lift 1641

When extra lifting range is important



SUREHANDS®



- Lifts up to 441 Lbs / 200 kg
- An integrated spreaderbar for convenience and use with Handi-slings
- Emergency down feature
- Ergonomic handle bar provides smooth steering making it easy to maneuver
- Width adjustable base for easy positioning. Low profile chassis with easy-to-roll castors for clearance under low objects
- Extended vertical lifting range for lifting from the floor onto a high bed or change table and for assisting with standing and ambulation where indicated



Specialists in innovative and reliable lift & care systems

www.surehands.com

Mobile lift 1641

Dimensions (inch / mm)

A	55.91 / 1420
B	27.76 / 705
B'	19.88 / 505
B1	50.2 / 1275
C	19.29 / 490
C1	11.02 / 280
C2	20.28 / 515
D	4.33 / 110
H	17.52 / 445
H'	52.56 / 1335
H1	44.49 / 1130
H2	70.08 / 1780
H3	79.92 / 2030
L	48.43 / 1230
L'	20.87 / 530
L1	54.13 / 1375
L2	56.1 / 1425
T	22.83 / 580
T'	5.71 / 145

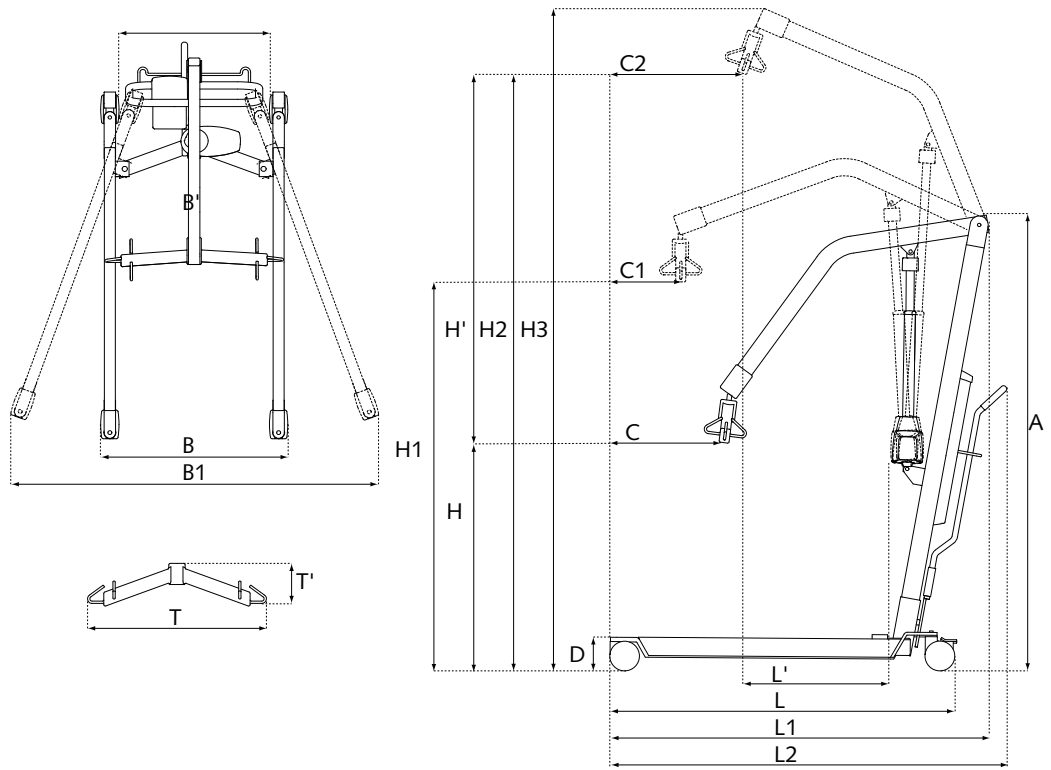

Specifications

Max. lifting capacity	441 Lbs / 200 kg
Emergency down	mechanical
Weight	106 Lbs / 48 kg
Batteries	sealed and maintenance-free 2 x 12 Vdc; 6,5 - 7,2 Ah
Number of lifts with fully charged batteries	120 at 198.42 Lbs / 90 kg / 19.69 inch / 50 cm
Charger	input: 0.9 A 100 - 240 Vac 50 -60 Hz, class II output: 24 Vdc Max 1.3 A
Turning radius	53.94 inch / 1370 mm

Speeds (inch/cm per sec.)

Raising (unloaded)	1.34 / 3.40
Lowering (unloaded)	1.34 / 3.40
Raising (load 198 Lbs / 90.00 kg)	1.1 / 2.80
Lowering (load 198 Lbs / 90.00 kg)	1.22 / 3.10
Raising (max. load)	0.83 / 2.10
Lowering (max. load)	1.06 / 2.70

Local Representative



Lift & Care® is a registered trademark of T.F. Herceg, Inc. dba SUREHANDS LIFT & CARE SYSTEMS.

© 14-09-2017 • Handi-Move • v2.4